

EC Axial Fan ZL250

风量曲线:

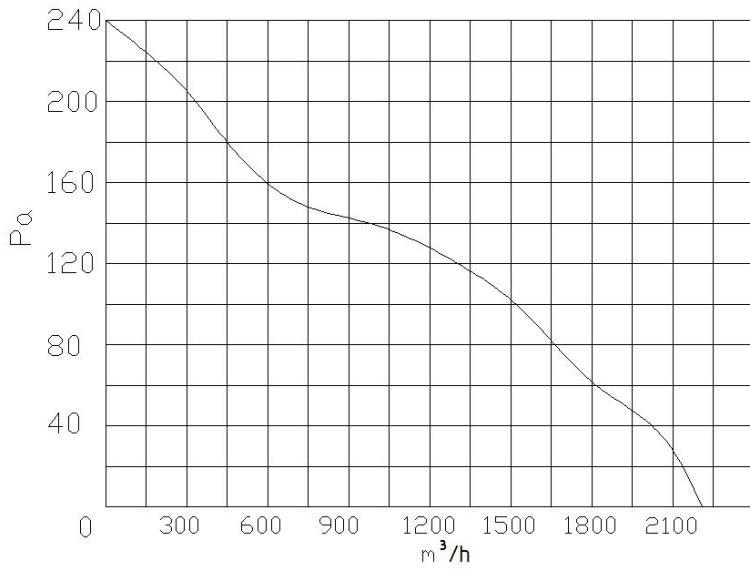

技术参数 Specifications

材质 :镀锌钢板 防护等级:IP44 绝缘等级:Class:B

| 型号 Model | 额定电压 Rated Voltage | 工作电压 Operating Voltage | 额定电流 Rated Current | 额定功率 Rated Power | 额定转速 Rated Speed | 风量 Air Flow | 风压 Air pressure | 噪音 Noise Level | 工作温度 Perm.Amb. Temp. | 质量 Weight |
|-------------|-----------------------|---------------------------|-----------------------|---------------------|---------------------|----------------|--------------------|-------------------|-------------------------|--------------|
| Part NO. | VAC | VAC | A | W | RPM | M³/h | Pa | dBA | °C | Kg |
| ZL250E2B1 | 230 | 184~264 | 1.45 | 180 | 3000 | 2200 | 240 | 69 | -25~+60°C | 2.4 |

外形尺寸 Outline

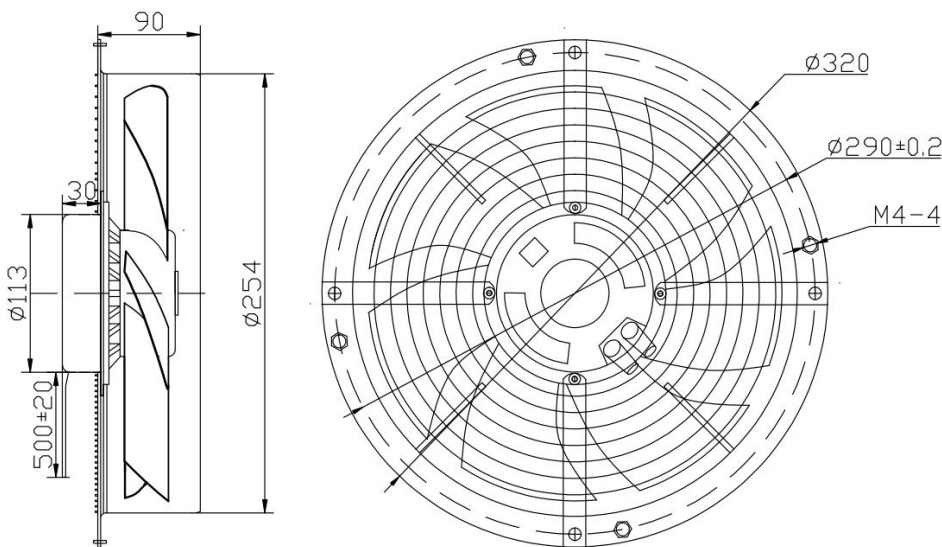

电源线 AC Power Cable 控制线 Control Cable

| 颜色 Color | 功能 Function | 颜色 Color | 功能 Function |
|-------------|----------------|-------------|-----------------|
| 棕 Brown | L | 红 Red | +10V Output |
| 蓝 Blue | N | 蓝 Blue | GND |
| 黄/绿 Y/G | PE | 黄 Yellow | 0-10VDC/ PWM |
| | | 白 White | FG |

EC Axial Fan ZL300

风量曲线:

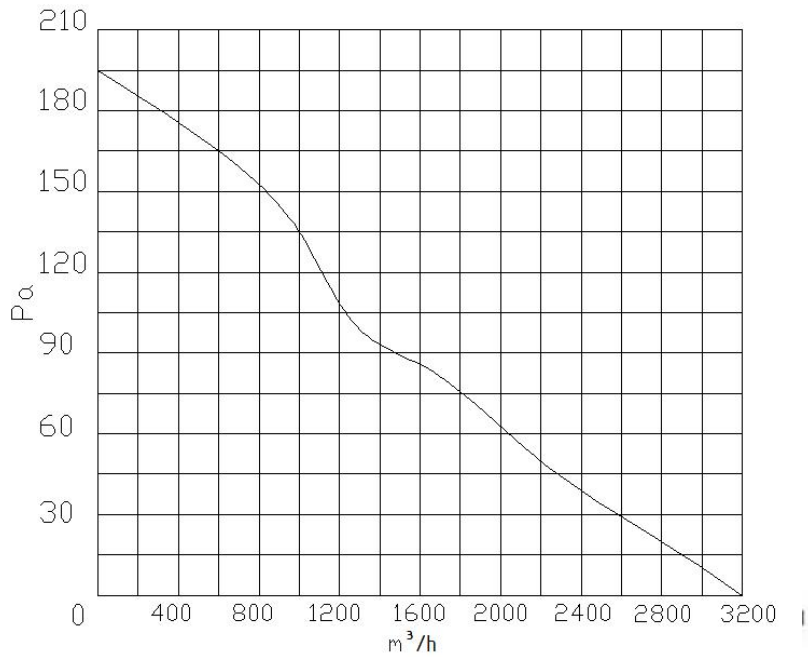

技术参数 Specifications

材质 :镀锌钢板 防护等级:IP44 绝缘等级:Class:B

| 型号 Model | 额定电压 Rated Voltage | 工作电压 Operating Voltage | 额定电流 Rated Current | 额定功率 Rated Power | 额定转速 Rated Speed | 风量 Air Flow | 风压 Air pressure | 噪音 Noise Level | 工作温度 Perm.Amb. Temp. | 质量 Weight |
|-------------|-----------------------|---------------------------|-----------------------|---------------------|---------------------|-------------------|--------------------|-------------------|-------------------------|--------------|
| Part NO. | VAC | VAC | A | W | RPM | M ³ /h | Pa | dBA | °C | Kg |
| ZL300E2B2 | 230 | 184~264 | 1.25 | 155 | 2300 | 3200 | 195 | 66 | -25~+60°C | 2.7 |

外形尺寸 Outline

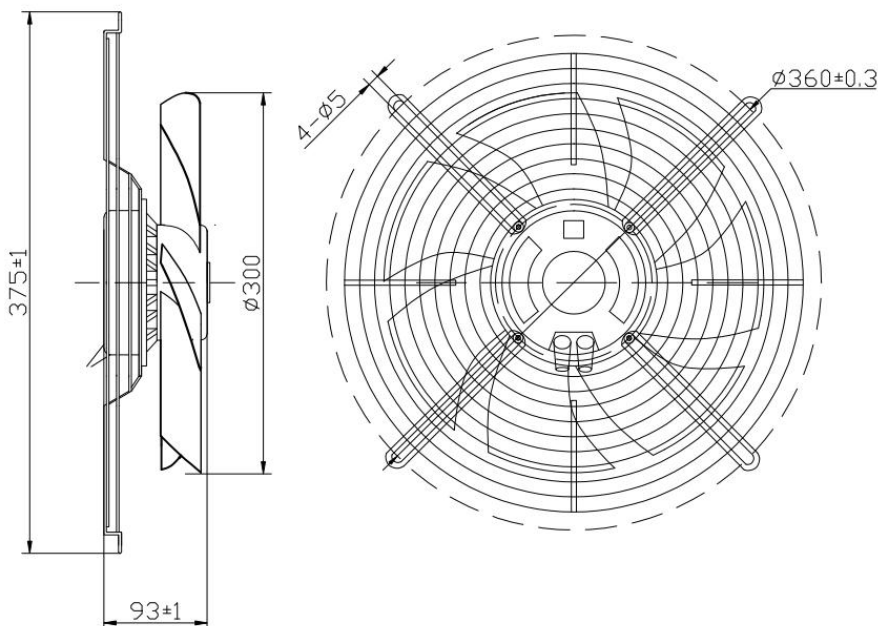

电源线 AC Power Cable 控制线 Control Cable

| 颜色 Color | 功能 Function | 颜色 Color | 功能 Function |
|-------------|----------------|-------------|-----------------|
| 棕 Brown | L | 红 Red | +10V Output |
| 蓝 Blue | N | 蓝 Blue | GND |
| 黄/绿 Y/G | PE | 黄 Yellow | 0-10VDC/ PWM |
| | | 白 White | FG |

EC Axial Fan ZL350

风量曲线:

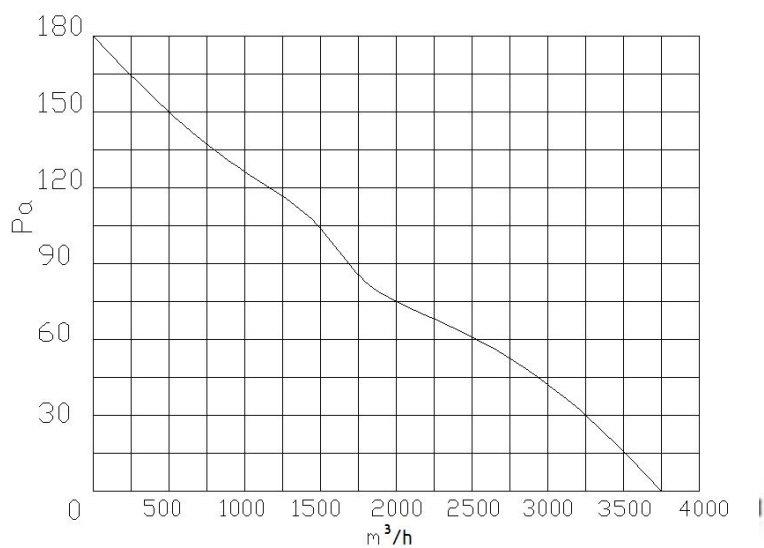

技术参数 Specifications

材质 :镀锌钢板 防护等级:IP44 绝缘等级:Class:B

| 型号 Model | 额定电压 Rated Voltage | 工作电压 Operating Voltage | 额定电流 Rated Current | 额定功率 Rated Power | 额定转速 Rated Speed | 风量 Air Flow | 风压 Air pressure | 噪音 Noise Level | 工作温度 Perm.Amb. Temp. | 质量 Weight |
|-------------|-----------------------|---------------------------|-----------------------|---------------------|---------------------|-------------------|--------------------|-------------------|-------------------------|--------------|
| Part NO. | VAC | VAC | A | W | RPM | M ³ /h | Pa | dBA | °C | Kg |
| ZL350E2B2 | 230 | 184~264 | 0.95 | 125 | 1750 | 3750 | 180 | 65 | -25~+60°C | 2.8 |

外形尺寸 Outline

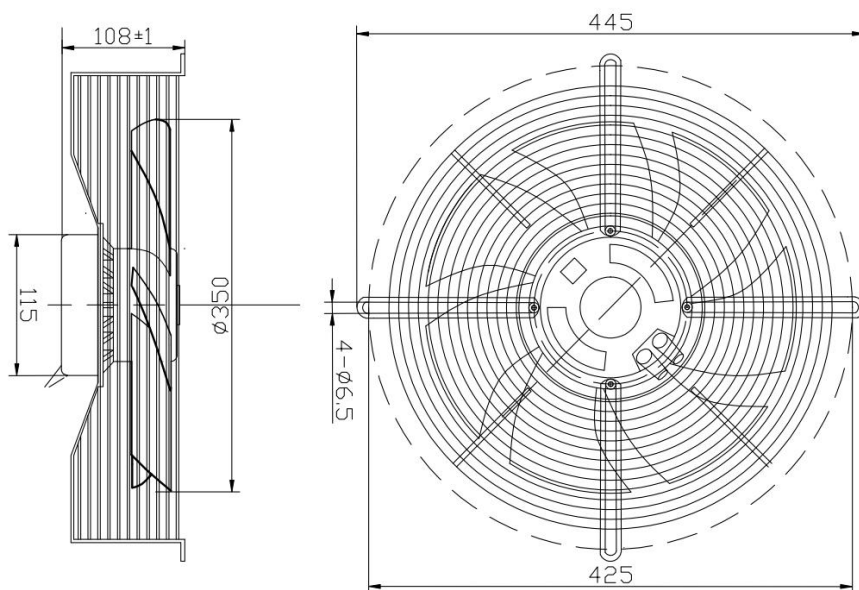

电源线 AC Power Cable 控制线 Control Cable

| 颜色 Color | 功能 Function | 颜色 Color | 功能 Function |
|-------------|----------------|-------------|-----------------|
| 棕 Brown | L | 红 Red | +10V Output |
| 蓝 Blue | N | 蓝 Blue | GND |
| 黄/绿 Y/G | PE | 黄 Yellow | 0-10VDC/ PWM |
| | | 白 White | FG |